

The background of the advertisement features a close-up, artistic rendering of a compressor's internal components, specifically two interlocking gears. The gears are metallic and highly detailed, with numerous teeth visible. The lighting is dramatic, highlighting the curves and surfaces of the metal. The overall color palette is dominated by various shades of green, from deep forest greens to bright, almost neon greens, which are used to create a sense of motion and energy. Swirling, blurred lines of light in shades of green and blue sweep across the scene, suggesting high-speed rotation. The text is overlaid on this dynamic background.

Zgaiard

OIL INJECTION AIR COMPRESSOR

mitsubishi
SEIKI

Z screw

a world-class compression mechanism

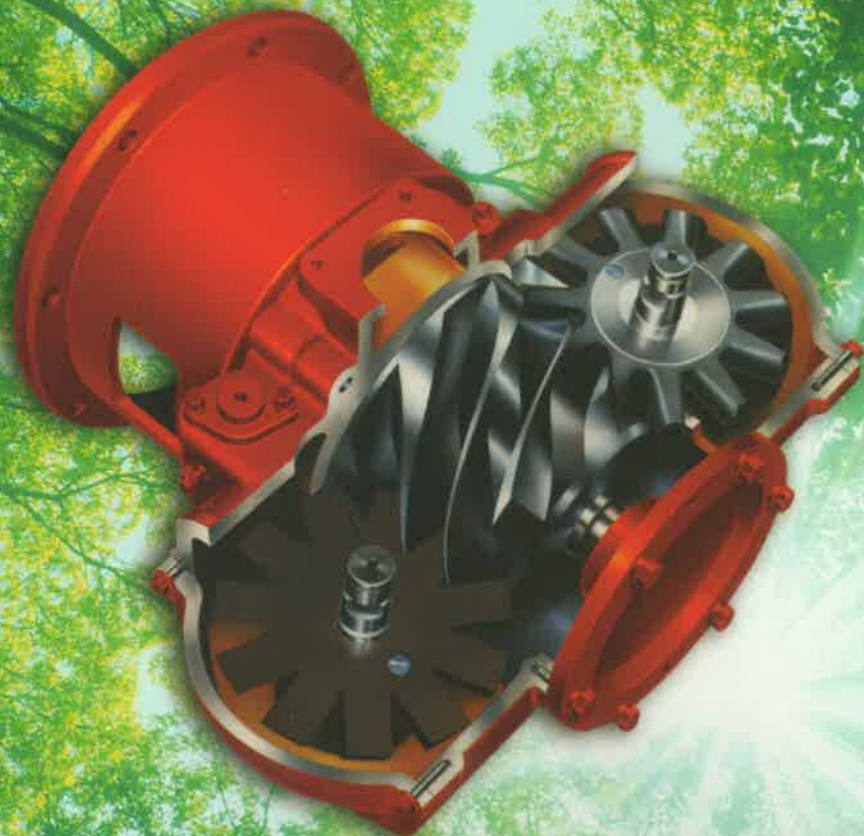

Evolution of Zscrew is evolution of compressor itself.

Z-series is indeed the origin of the product series of the Mitsui Air Compressor. Since launched the Z screw air compressor on 1972, we have constantly responded the needs of the times that change day by day to evolve it as a high efficient, energy saving air compressor. Then, we launched the inverter controlled ZV series that have been improved to deal with the ongoing environmental issues. Now we have lined up the lower noise and space saving advanced model (Zgaiard) mounting the brand-new IPM (permanent magnet) motor to meet users' expectation. Please note also that the Scroll air compressor series(Escal), that have been receiving good reputations since their launching on 1988, are now graded up to have the more high efficiency and energy saving capability. They are most appropriate for countering the environmental issues to be required by the Earth and Industries.

Compressors design

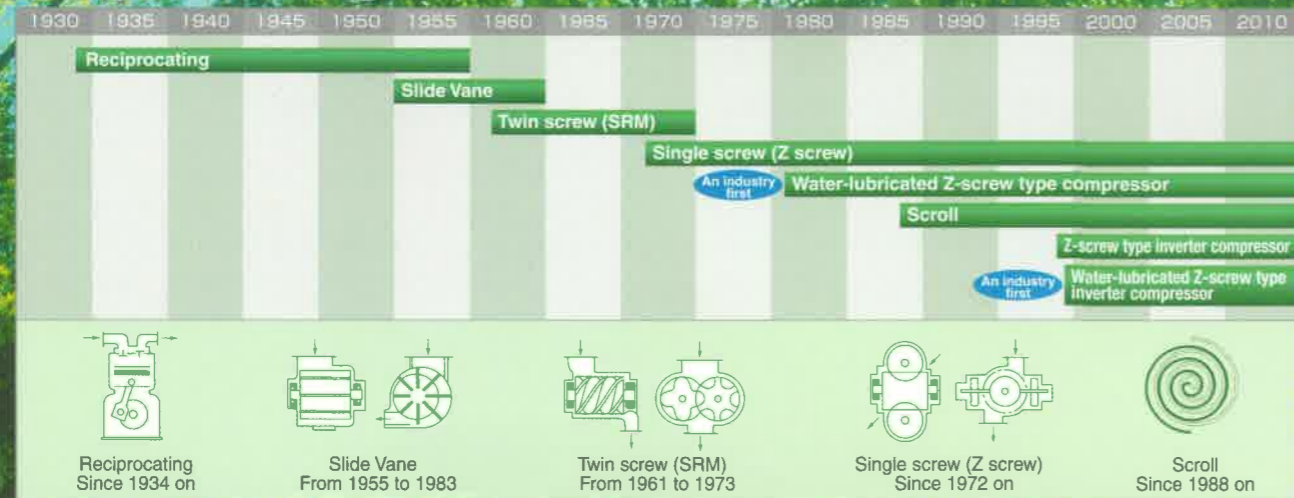

Simple construction and sealing effect realize excellent performance.

Primary factor of high efficiency and durability of "Z screw" is achieved by sealing gaps of each portion with oil in good balance by simple constitution consists of one screw rotor and two gate rotors. It holds noise and vibration in a minimum whereas efficiency does not deteriorate in low rotation either. "Z screw" of this superior mechanism. It extends the maintenance cycle marvelously and represents maximum capability in the inverter control.

Comparison of Z screw with Dry Twin screw

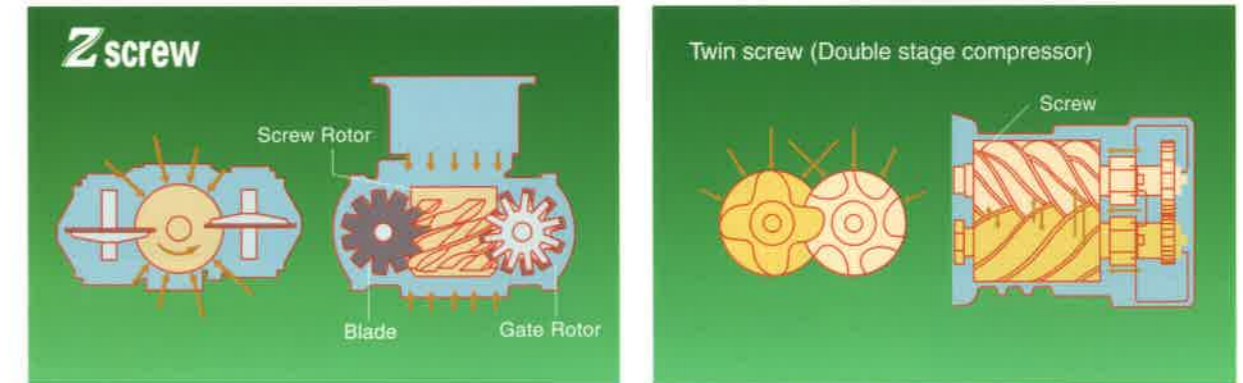

•Radial and axial loads eliminate each other, theoretically resulting a zero load

•Radial load and distance between the two screw axles place significant limitations on bearing load

Air flow

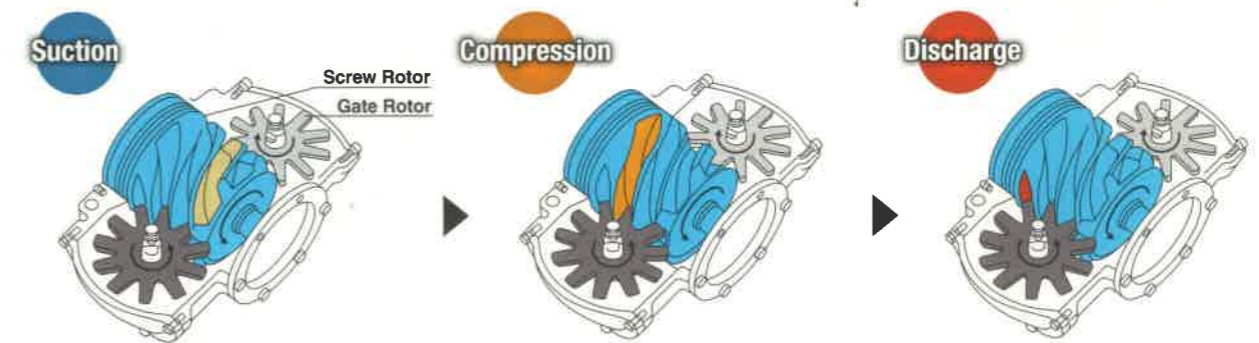

High reliability implemented by the precision

High precision technology of the MITSUI SEIKI, also known as a machine tool manufacturer, is utilized on processing the compression section to make up the Z screw air compression mechanism that realizes the high efficiency and high stability.

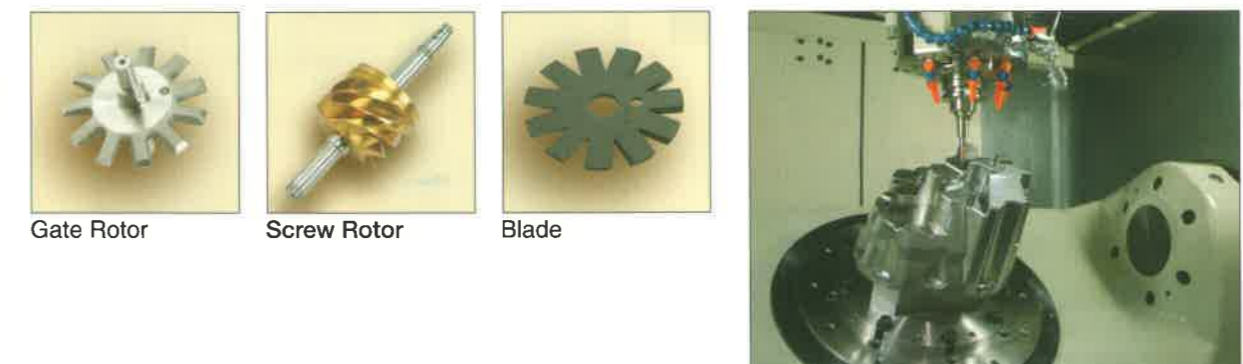

We offer a wide lineup of products to apply

MITSUI SEIKI OIL INJECTION TYPE SCREW COMPRESSOR SERIES

for any needs, from compact to large units.

Ultimate high productive and energy saving achieved by the inverter control

Zgaiard

Inverter Compressor

Air cooled 7.5~37kW
(option: water cooled 22 / 37kW)

7.5kW / 11kW / 15kW / 22kW / 37kW

●7.5~15kW

- Inverter
- Environmentally friendly
- High efficiency
- Red-CX compatible
- Energy saving
- Space saving
- IPM motor
- Increasing
- IT touch panel
- Red-CX compatible
- Z-mate compatible
- Energy saving
- Environmentally friendly
- High efficiency
- Air cooled fan inverter
- Space saving

●22~37kW

- Inverter
- Energy saving
- Environmentally friendly
- High efficiency
- Air cooled fan inverter
- Space saving



Details ▶ 5,6

Basic type with simple design optimized for environmental performance

Zgaiard

Basic Compressor

Air cooled 7.5~37kW
(option: water cooled 22 / 37kW)

7.5kW / 11kW / 15kW / 22kW / 37kW

- Red-CX compatible
- Energy saving
- Environmentally friendly
- High efficiency
- Space saving



Details ▶ 8

Zgaiard

Inverter Compressor

Air cooled 55 / 75kW
55kW / 75kW

Water cooled 55 / 75kW
55kW / 75kW

- Inverter
- IT touch panel
- Energy saving
- Air cooled fan inverter
- IPM motor
- Red-CX compatible
- Environmentally friendly
- Space saving
- Increasing
- Z-mate compatible
- High efficiency



Details ▶ 7

Zgaiard

Basic Compressor

Air cooled 55 / 75kW
55kW / 75kW

Water cooled 55 / 75kW
55kW / 75kW

- Red-CX compatible
- High efficiency
- Energy saving
- Space saving
- Environmentally friendly



Details ▶ 9

Zgaiard

Basic Compressor

Air cooled 100 / 150kW
100kW / 150kW

Water cooled 100 / 150kW
100kW / 150kW

- Red-CX compatible
- High efficiency
- Energy saving
- Space saving
- Environmentally friendly



Details ▶ 8

Zgaiard

Inverter Compressor

Air cooled 100 / 150kW
100kW / 150kW

Water cooled 100 / 150kW
100kW / 150kW

- Inverter
- Environmentally friendly
- IPM motor
- High efficiency
- Red-CX compatible
- Energy saving
- 100kW/150kW inverter is option



Details ▶ 7

Advanced scroll type

Escal series



Air cooled 3.7 / 5.5kW

- Energy saving
- Environmentally friendly
- High efficiency

Details ▶ 10

Energy saving machine

Plural control system

Red CX



- Averaging operating time
- Alternate operation
- Permanent fixed operation
- Start and stop in fixed order
- Averaging the operating time of inverter machine
- Turn back control
- 2patterns of pressure settings by weekly timer



Receiver tank

- Instantaneous consumption
- Energy saving
- Lengthen machine's lifetime
- Stable pressure supply

Details ▶ 11,12

Inverter Compressor **Zgaiard series** 7.5~37kW

MITSUBISHI SEIKI OIL INJECTION TYPE SCREW COMPRESSOR SERIES

Zscrew on new stage to head for future.

Compact, Quiet, and New Design

We have achieved the industry's most compact, space-saving design, through considerations for the compressor's setup environment. Also, we have achieved the industry's quietest performance for noise values. New design with high-quality metallic coloring. Color LCD touch-panel is standard for 22-37kW model. Improved operability and easy-maintenance through scheduled and alternate operation.

Reduced power amounts

33% Reduced

Annual power consumption

1.19 million yen/year Reduced

Annual CO₂

44t/CO₂ Reduced

(Air Discharge Volume of 60%) (37 kW, 0.7 MPa)

| Machine Name | ZV08AS4-R | ZV11AS4-R | ZV15AS4-R | ZV22AS4i-R | ZV37AS4i-R |
|--|-----------|-----------|-----------|------------|------------|
| Reduced Power (kWh) | 2.5 | 3.8 | 5.0 | 7.7 | 13.2 |
| CO ₂ Reduction Amount (ton/CO ₂ /Year) | 8 | 13 | 17 | 25 | 44 |
| Reduced Power Costs (Thousands/Yen/Year) | 220 | 340 | 450 | 690 | 1,190 |

- Air Discharge Volume: 60%
- Power Charges: 15 yen/kWh
- Running Time: 6,000 h/year
- CO₂ emission is calculated at 0.550kg/kWh (ratio is decided by power company of each region.)

Power consumption

11% Reduced

(by lowering pressure from 0.7MPa to 0.55MPa)

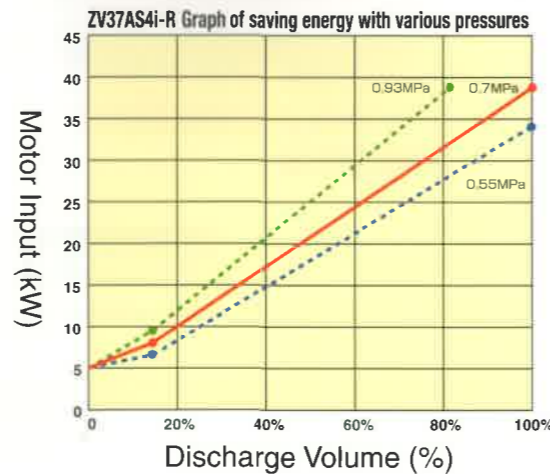
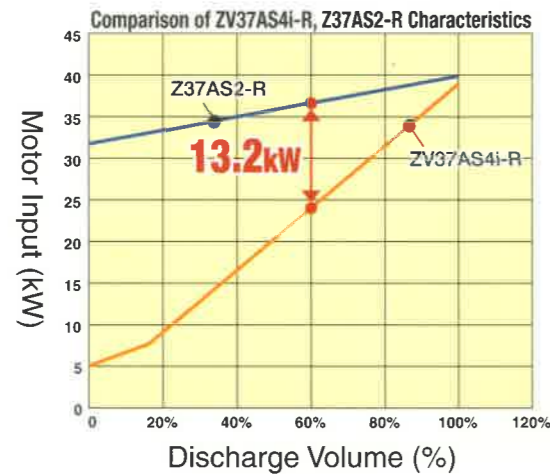

Quiet Performance

- 3dB (A)* quieter from the previous model!
- Achieves industry's quietest performance. *Comparison of 15kW machine
- Fan Inverter control (Non-step control of fan speed to maintain discharge temperature under 90°C.)

Space-saving and Stylish looking

- Setup floor space is 30%* less than the previous model! *Comparison of Z37 machine
- Fits right up against wall because we have eliminated the back-side air intake.

Improvement of the frame's stiffness

- The frame's stiffness has been improved so that it can perform sufficiently wherever it is placed.
- We analyzed the structure of machine when it is supported in 3 points and when it is carried by forklift truck. The amount of deformation has been reduced by half.



Next Generation LCD Monitor (optional for Z series)

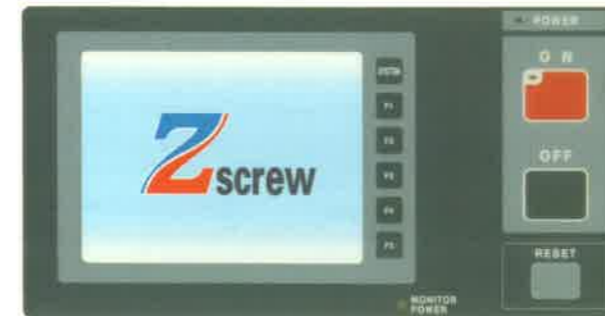

- Color LCD Touch panel - easy and simple control (For ZV22kW & 37kW)
- The IT touch panel enables you to make quick selections on a diverse menu simply by touching the screen. Setting schedule operations or data sampling and maintenance works are much easier with this color monitor - bright and easy-to-see.

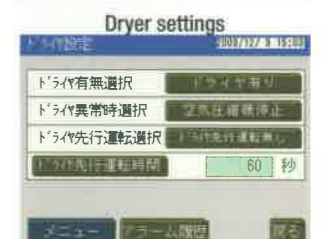
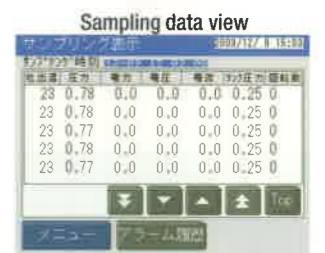
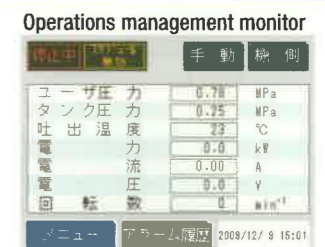

- Supports power outages for up to 20 seconds for automatic restarts
- Scheduled operation
- Alternate operation
- Supports Z-mate (PC monitoring)
- Download sampling data to PC.

- Data sampling temperature/pressure/power/voltage/current/tank pressure/speed

Alternate operations feature

You can alternately operate up to two units of the new Zgaiard. If you combine this with the scheduled operation, you can switch main and subordinate machine on specific days.

Select the Optional System to Suit Your Needs

Monitor operating status in real time Remote Monitoring System Z-mate

From a computer, you can monitor the operating status of up to 10 air compressors connected over a in-house LAN system or other Ethernet connection. You can also save monitoring data and operating air compressors by remote control.

*Only air compressor models with a built-in LCD monitor IT touch panel can be connected.

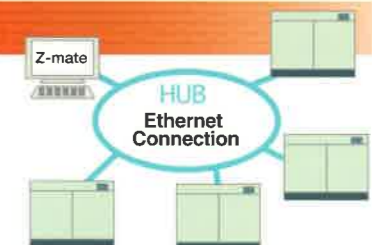

Ethernet is a registered trademark of Xerox Corp.

Inverter Compressor Zgaiard series 55 / 75kW

MITSUBISHI SEIKI OIL INJECTION TYPE SCREW COMPRESSOR SERIES

Ultimate high productive and energy saving achieved by inverter control



- Color liquid crystal touch panel monitor with "scheduled operation" and "alternate operation"
- Be able to memorize and output operating conditions.
- "Inverter-controlled Fan Motor" can save more energy.
- Having instant-starting system, there's no trouble of delay of pressure when it suddenly stopped by blackout or automatic operation.

Space-saving and Stylish looking

- Setup floor space is 17%* less than the previous model!
*Comparison to the previous ZV75 machine
- Powerful and dignified styling.

Improvement of the operability

- Color LCD touch-panel
- With instant-starting system, it can be rebooted quickly.

Environmental measure

- IPM Motor direct connection drive with no power loss.
- Optimum temperature control enables less drain generation.
- It doesn't go abnormal stop when ambient temperature is 45°C
*Using over 40°C environment shortens life span of electrical component. *only dryerless.
- Improved high efficient dryer. Using new alternative CFCs, R-410A. Reducing refrigerator consumption 22%

Reduced power amounts
30% Reduced
Annual power consumption
1.86 million yen / year Reduced
Annual CO₂
68 t / CO₂ Reduced

(Air Discharge Volume of 60%) (75 kW, 0.7 MPa)

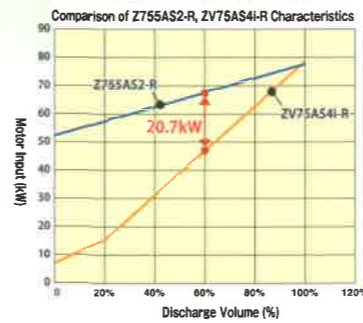

Zgaiard series Basic type 7.5~37kW

MITSUBISHI SEIKI OIL INJECTION TYPE SCREW COMPRESSOR SERIES

Compact but powerful basic type



Powerful compact machine with direct motor connection.

Space-saving and Stylish looking

- Setup floor space is 22%* less than the previous model!
*Comparison of Z15 machine
- Powerful and dignified styling
- Fits right up against wall because we have eliminated the back-side air intake.



Maintenance saving

- Motor direct connection drive with no power loss
- Maintenance works applicable from front shutter
- No belt maintenance realized by Direct drive
- Long life cycle realized by decreased Bearing load



Simple structure

- Reduced piping
- Removal of consumable parts through one-touch operation
- Most appropriate direct drive with Z screw



Environmental measure

- Adopted an environmentally-friendly alternative Freon R-407C to prevent ozone layer destruction.
- Adopted the SUS plate type dryer heat exchanger. Improved anti-corrosion. (Z08~15)
- Dryer heat exchanger capacity up. (Z08~15)

Inverter Compressor Zgaiard series 100/150kW

MITSUBISHI SEIKI OIL INJECTION TYPE SCREW COMPRESSOR SERIES

Only Z screw can realize high efficiency equal to single or double stage compressor.



- IT Package (option)
- IT touch panel,
 - Scheduled operation power restarts,
 - Alternate operation,
 - Remote monitoring system

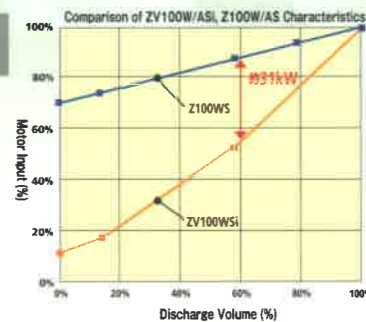

100kW
Reduced power amounts
35% Reduced
Annual power consumption
2.79 million yen / year Reduced
Annual CO₂
102 t / CO₂ Reduced
(Air Discharge Volume of 60%) (100 kW, 0.7 MPa)

150kW
Reduced power amounts
38% Reduced
Annual power consumption
4.5 million yen / year Reduced
Annual CO₂
165 t / CO₂ Reduced
(Air Discharge Volume of 60%) (150 kW, 0.7 MPa)

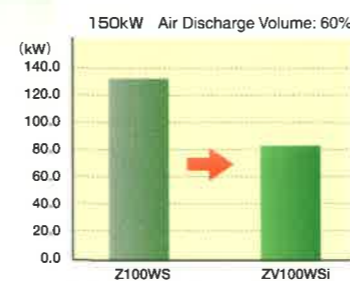
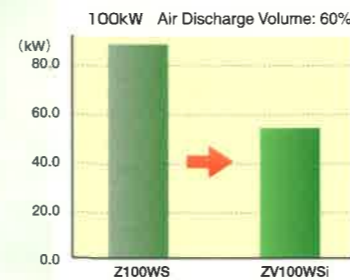

- Air Discharge Volume: 60%
- Power Charges: 15 yen/kWh
- Running Time: 6,000 h/year

Zgaiard series Basic type 100/150kW

MITSUBISHI SEIKI OIL INJECTION TYPE SCREW COMPRESSOR SERIES

Larger effect of energy saving by the combined operation of standard machine and inverter machine

The effectiveness can be maximized with Basic machine operates at full load and Inverter machine to absorb load variation.

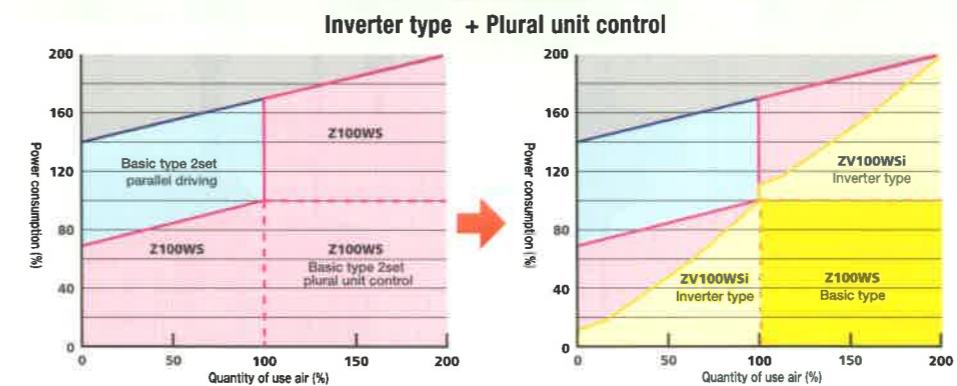

Z series Basic type 55/75kW

MITSUBISHI SEIKI OIL INJECTION TYPE SCREW COMPRESSOR SERIES



Z screw 55kW/75kW

Z series is the origin of Mitsui Seiki air compressor. Z555AS3-R

Long life cycle and reduction of maintenance works

- Setup floor space is 12%* less than the previous model.
- Environment-Friendly Plastic Paint.

Environmental response

- Using new alternative CFCs, R-410A.
- Reducing refrigerator energy consumption 22%.
- It doesn't go abnormal stop when ambient temperature is 45°C.

Reduction of Maintenance works

Maintenance work from the front door.
Realized the man-hour reduction

Long life maintenance

- ① Oil replacement → 6,000 hrs
- ② Oil separator element replacement → 6,000 hrs
- ③ Oil filter replacement → 6,000 hrs
- ④ Air cleaner element replacement → 650mmAq

*Maintenance cycle varies depending on the operating condition. Remember the sooner action.
*Add the oil when oil decreased during operation.
*Replace the whole oil when replacing it.

What is "Efficient Compressor" ? ... EB-unit

Mitsui Seiki use EB-unit (Energy Basic-unit) to describe how efficient compressor is to help customers correctly evaluate energy performance of each compressors.

$$EB\text{-unit}(kW/m^3/min) = \text{Compressor Shaft Power}(kW) \div \text{Air Delivery}(m^3/min)$$

For Inverter Compressor

$$\text{Compressor Shaft Power}(kW) = \text{Input Electricity}(kW) \times \text{Total Efficiency}(\text{Inverter Efficiency} \times \text{Motor Efficiency})$$

EB-unit indicates how much energy is needed to produce 1m³/min air.
Smaller EB-unit is better efficiency.

| Zgaiard ZV series | Zgaiard ZV08AS4-R | Zgaiard ZV11AS4-R | Zgaiard ZV15AS4-R | Zgaiard ZV22AS4i-R | Zgaiard ZV37AS4i-R | Zgaiard ZV55A/WS4i-R | Zgaiard ZV75A/WS4i-R | Zgaiard ZV100A/WSi | Zgaiard ZV150A/WSi |
|------------------------------------|-------------------|-------------------|-------------------|--------------------|--------------------|----------------------|----------------------|--------------------|--------------------|
| Compressor Shaft Power (kW) | 7.5 | 11 | 15 | 22 | 37 | 55 | 75 | 100 | 150 |
| Air Delivery (m ³ /min) | 1.2 | 1.8 | 2.6 | 3.8 | 6.4 | 9.5 | 13.0 | 19.0 | 26.0 |
| EB-unit (kW/m ³ /min) | 6.25 | 6.11 | 5.77 | 5.79 | 5.78 | 5.79 | 5.77 | 5.26 | 5.77 |

*"EB-unit" is Mitsui Seiki original naming of energy efficiency.

Mitsui Z Screw

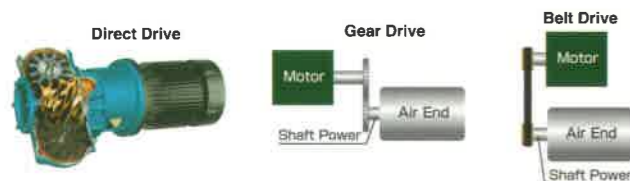

If there is gear or belt between motor and air end, mechanical loss occurs and affect efficiency. Some compressor manufacturers use Service Factor. In this case, Motor Output(kW) on the catalog and actual Shaft Power(kW) would be different.

Mitsui Seiki Z screw compressor is Direct Drive = No Mechanical Loss. Motor Output and Shaft Power are equal.

Unprecedented compression mechanism implemented by long experience ...

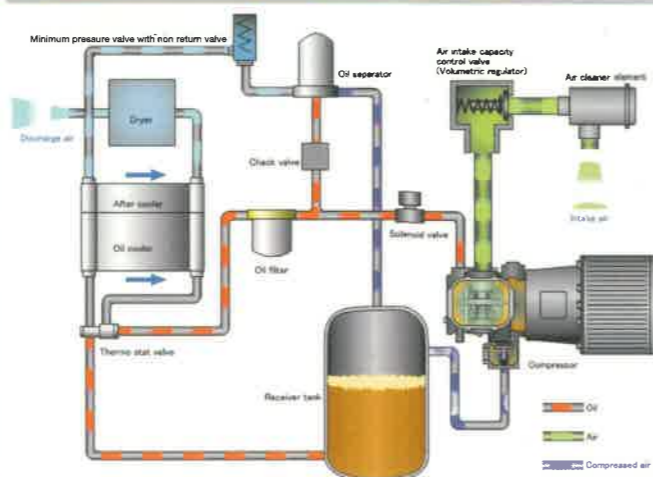

Escal series 3.7/5.5kW

MITSUBISHI SEIKI OIL INJECTION TYPE SCROLL COMPRESSOR SERIES



ESCAL45R

Scroll compressor 3.7kW/5.5kW

Advanced scroll air compressor Escal applicable to meet the 21st century. Compact unit most appropriate to deal with environmental issues adding to its established performance and realized high efficiency and energy saving

Scroll air compressor to deal with environment and energy saving

Escal's Quiet

Non-contact and low noise, low vibration scroll rotation without tip sealing is achieved by the high precision machining center of MITSUI SEIKI.

Compression process of the Scroll compressor

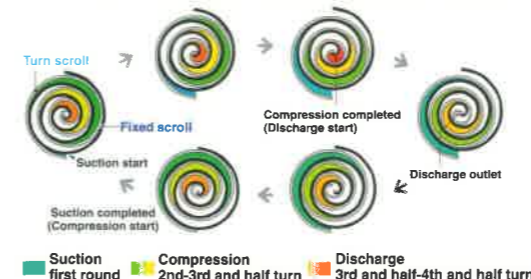

Escal's Kindness

- Safety-friendly protective devices (against motor overload, discharge temperature error, Dryer error, reversed phase)
- Adopted an environmentally-friendly alternative Freon R-407C of ozone layer depletion coefficient zero
- Unit layout considering the operation ability based on ergonomics.

Escal's Energy-saving

Auto start/stop system combined with the high energy saving unloader system. Applicable to deal with the intermittent and continuous operation. Also applicable to set the continuous unloader system depending on the air application condition.

Escal's Power

High efficient power created by gentle and smooth revolution. Overwhelming delivery airflow volume maximum in the class is presented by sealing effect of oil membrane continually created in compression chamber.

Delivery air volume comparison 3.7 kW unit:



Escal's Functionality

- Monitor panel pursuing simple use
Featured is exceeded operation ability equipped with the Operation status display, Error display, Maintenance display and so on as self-diagnosis function.
- Auto dry timer as standard equipment to prevent the occurrence of drain. It automatically controls any drain likely to occur when the humidity was high or operation load was low.
- Mounted with the totally-enclosed external fan motor to confront dust and humidity.
- Applicable to set the advance operation of the Dryer. The Dryer shall start working first and Air Compressor automatically starts working one minute after.

Escal's Reliability

- Drastically improved reliability and durability of the air dryer.
- A heat exchanger is plate-type made of all stainless steel.
- The air dryer became compact due to big heat conduction coefficient.
- Reduce pressure loss to 1/3 of past model.



Escal's Maintenance capability

- Its filter element is a cartridge type, which is easily replaceable by opening the front shutter.
- Tip seal need changing is not used.



Regulate Eco Drive Controller

Attempts energy saving by driving minimum required numbers of plural air compressors according to air consumption (Maximum controlled unit: eight unit.). Digital pressure indication enables driving of the minimum number in precise pressure range. Further energy saving is materialized by combination of inverter machine and standard un-loader machine or plural unit control of inverter machine only.

Option lineup

Custom specifications are ready to meet the needs of clients

ZV&Z Control ZV 75kW X1set + Z 75kW X3set Free air delivery 52m³/min

In case of 1 set of inverter machine

Inverter machine runs preceding and stops last. Ideal driving is enabled as the standard machine runs with full load whereas the inverter machine runs by controlled number of the rotation depending on load fluctuation.

In case of plural number of inverter machines

Double loop driving with rotation function of inverter machine is viable.

Applicable to control the inverter unit for all types

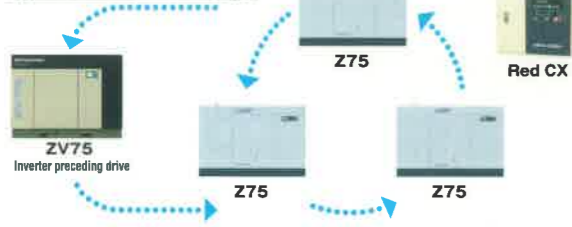

Simulation of Air usage conditions: Max46m³/min ↔ Min20m³/min

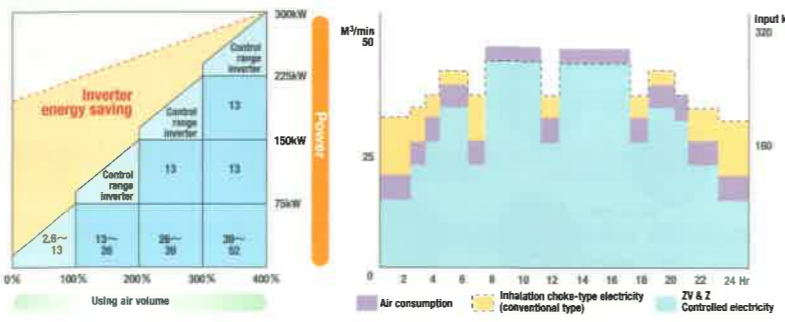

Function of plural unit Control System

Averaging operating time

Pressure sensor detects air pressure and starts / stops compressor. Red CX chooses which compressor to start / stop in order to average the operating time. Having operated for a certain time, running compressor averages the operating time in rotating.

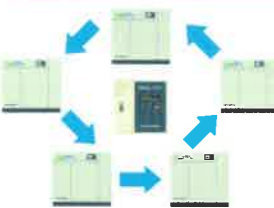

Alternate operation

You can operate main machine and subordinate machine alternately. When the main machine has run for a certain time, subordinate one starts to run in exchange so that operating time is averaged.



Permanent fixed operation

You can set which compressor to run all the time. The fixed compressor starts to operate first and continue running. The other compressors can be running in all operation pattern.

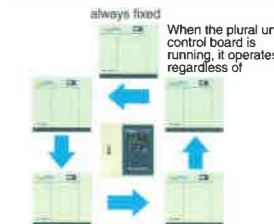

Start and stop in fixed order



Averaging the operating time of inverter machine



If you use both standard machine & inverter machine Standard machine runs in the way averages the operating time. Inverter machine rotates in optional time.

Turn back control

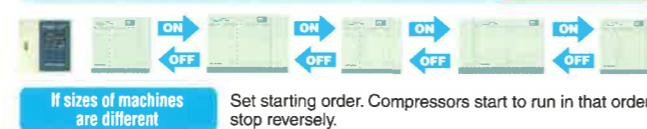

2 pattern of pressure setting by weekly timer

ex.) You can set different pressure day and night / weekdays and the weekend.

Receiver tank

- Material** SS400·SM490A
- Color** Munsell 7.5Y7/1
- Attachment** safety valve, pressure gauge, drain valve
- Certification** the second sort pressure vessel certificate



| Applicable compressor | Tank capacity (L) |
|-----------------------|-------------------|
| 3.7~5.5kW | 100~200 |
| 7.5~15kW | 200~400 |
| 22kW | 400~700 |
| 37kW | 700~1000 |
| 55kW | 1000~2000 |
| 75kW | 1500~3000 |

※Further, for general application, it is recommended to install the air tank of delivery air capacity 10~20%.

※Please ask us when you choose vessel's volume in terms of pressure, air consumption or holding time.

| Model | Tank capacity (L) | Maximum allowable pressure (MPa) | Mass (kg) | Outer diameter D (φ mm) | Height H (mm) | Air outlet / inlet connection diameter | |
|--------|-------------------|----------------------------------|-----------|-------------------------|---------------|--|--------|
| | | | | | | Socket | Flange |
| MTA-01 | 98 | 1.00 | 60 | 359 | 1400 | Rc3/4 | |
| MTA-02 | 201 | 1.00 | 115 | 462 | 1660 | Rc1 | |
| MTA-03 | 298 | 1.00 | 150 | 512 | 1921 | Rc1-1/2 | |
| MTA-04 | 395 | 1.00 | 180 | 612 | 1863 | Rc1-1/2 | |
| MTA-05 | 498 | 1.00 | 270 | 666 | 1978 | Rc1-1/2 | |
| MTA-07 | 698 | 1.00 | 330 | 766 | 2072 | | 50A |
| MTA-10 | 991 | 1.00 | 440 | 868 | 2253 | | 50A |

※About 1500~6000L vessels, please ask us .

※If you use oil-free air, we recommend having inside epoxy-coated(option).

※There is no duty to submit registration of vessel setting, please observe safety regulation of boilers and pressure vessels based on Industrial Safety and Health Act.

※Designs of product may be changed without permission. Ask us about detailed information.

Clean air system

Put a combination of various filters in the piping in proportion to the required air cleanliness to obtain much more clean compressed air.



| use | result |
|---|--|
| Line filter Air tool, Air motor, Air press, general painting, spray lubrication | Dry air nominal filtering rating : 1~5 μm In such a case that inclusion of a certain oil or dust after waterelimination was allowed. |
| Line filter + mist filter For instrumentation, static painting, dry, electronic parts | Dry and oil eliminated air nominal filtering rating : 0.1~0.01 μm In such a case that the air eliminated almost all the water, oil and dust was required. |
| Line filter + mist filter + activated carbon filter For medicament, food, brewing, ozone generator, scientific analysis equipment and caisson shielding | Dry, oil and smell eliminated air nominal filtering rating : 0.003~0.01 μm In such a case that the air eliminated almost all the water, oil, dust and smell was required. |

Custom specification option

- Medium pressure (1.3MPa) specification** Delivery pressure is set to 1.37MPa. Most appropriate for the use of Laser unit and the like (applicable to Z15, 22kW9)
- Low voltage volume increase specification** Discharge air volume shall be lowered to increase the delivery air volume (applicable to the Increasing type ZVi 22kW~75kW)
- 380V-400V different voltage** Applicable to change the main circuit voltage. Electricity 200V shall be self supplied to the Operation circuit and Dryer power supply through the Down transformer.
- Cold region specification** Countermeasure shall be supplied for the cold region to operate the unit in a safe condition. The unit shall automatically keep the heat when the atmosphere temperature dropped to prevent the Dryer and Drain from freezing up.
- Outdoor specification** Waterproof package applicable to install outdoor to confront the rain flooding.
- Water cooling type** Applicable to replace the cooling unit with a water cooling type when the application of the air cooling type was difficult under environmental condition such as not possible to ensure the ventilation (applicable to 22kW)
- ASME specification tank** Applicable to change the tank built-in the compressor to ASME code specification for delivery abroad (except for USA).

* Some specifications are not applicable depending on the unit type. Please contact us for details.

Zgaiard ZV series

• Inverter 7.5kW~75kW

| model | Zgaiard ZV06AS4-R | Zgaiard ZV11AS4-R | Zgaiard ZV15AS4-R | Zgaiard ZV22AS4-R | Zgaiard ZV37AS4-R | Zgaiard ZV55AS4-R | Zgaiard ZV75AS4-R | Zgaiard ZV55WS4-R | Zgaiard ZV75WS4-R |
|-----------------------------------|---|-------------------|------------------------|---------------------------------------|-------------------------|-------------------|------------------------|-------------------|--------------------------|
| Delivered air pressure (MPa) | 0.7 [0.60~0.93] | | 0.7 [0.54~0.93] | | 0.7 [0.54~0.93] (0.5) ※ | | | | |
| Free air delivery (m³/min) | 1.2 | 1.8 | 2.6 | 3.8 (4.5) ※ | 6.4 (7.1) ※ | 9.5 (11.0) ※ | 13.0 (14.0) ※ | 9.5 (11.0) ※ | 13.0 (14.0) ※ |
| Intake air pressure & temperature | Atmospheric pressure (2~40°C) | | | | | | | | |
| Main motor power (kW) | 7.5 | 11 | 15 | 22 | 37 | 55 | 75 | 55 | 75 |
| Power source voltage (50/60Hz,V) | 200/200-220 | | | | | | | | |
| Motor type | 3-phase squirrel cage, 2P totally-enclosed external fan | | | Totally enclosed fan cooled IPM motor | | | | | |
| Starter | verter starter | | | | | | | | |
| Drive system | Direct coupled motor | | | | | | | | |
| Cooling system | Air cooled | | | | | | Water Cooled | | |
| Fan motor power (kW) | 0.4 (Inverter control) | | 0.9 (Inverter control) | | 2.2 (Inverter control) | | 3.0 (Inverter control) | | 0.08/0.12, 0.08/12x2 |
| Oil fill ration (L) | 10 | | 13 | | 15 | | 20 | | 60 |
| Air dew point at outlet (°C) | 10 (under applied pressure) * | | | | | | | | |
| Cooling medium (kW) | 0.382/0.454-0.458 | 0.396/0.468-0.475 | 0.540/0.602-0.626 | 1.5/1.9 | 1.9/2.4 | 2.4/2.8 | 1.9/2.4 | 2.4/2.8 | |
| Discharge pipe diameter (R) | 3/4 | | 1 | | 1 1/2 | | 2 | | |
| Width (Dryer less) (mm) | 905 | | 1050 | | 1280 (1160) | | 1750 (1550) | | 2325 (1848), 2398 (1938) |
| Length (mm) | 705 | | 750 | | 1200 | | | | |
| Height (mm) | 1400 | | 1450 | | 1490 | | 1550 | | 1700, 1800, 1700, 1800 |
| Total mass (Dry state) (kg) | 430 | 450 | 560 | 590 | 830 | 1440 | 1630 | 1450 | 1600 |
| Noise level (dB (A)) | 52 | 53 | 54 | 54 | 59 | 66 | 69 | 64 | 65 |
| EB-unit (kW/m³/min) | 6.25 | 6.11 | 5.77 | 5.79 | 5.78 | 5.79 | 5.77 | 5.79 | 5.77 |

Cautions: Dryer of low pressure specifications (option) shall be separate type. Please contact us for dryer dimensions and mass.
 ※: Values in () are the free air delivery for 0.5MPa specification (option)
 * Values with ambient temperature of 30; and rated discharge pressure.
 ◎ Noise values measured in noiseless environment at distance of 1.5meters from front, at height of 1m, with load of 100% (at 0.7MPa)

Notation



Zgaiard ZV series

• Inverter 100kW / 150kW

| model | Zgaiard ZV100ASi | Zgaiard ZV150ASi | Zgaiard ZV100WSi | Zgaiard ZV150WSi |
|-----------------------------------|---------------------------------------|------------------|------------------|------------------|
| Delivered air pressure (MPa) | 0.7 [0.54~0.93] | | | |
| Free air delivery (m³/min) | 19.0 | 26.0 | 19.0 | 26.0 |
| Intake air pressure & temperature | Atmospheric pressure (2~40°C) | | | |
| Main motor power (kW) | 100 | 150 | 100 | 150 |
| Power source voltage (50/60Hz,V) | 400 | | | |
| Motor type | Totally enclosed fan cooled IPM motor | | | |
| Starter | Inverter starter | | | |
| Drive system | Direct coupled motor | | | |
| Cooling system | Air cooled | | Water cooled | |
| Fan motor power (kW) | 5.5 | | 0.15/0.22 | |
| Oil fill ration (L) | 80 | 100 | 80 | 100 |
| Discharge pipe diameter (R) | JIS 3B (80A) Flange | | | |
| Width (Dryer less) (mm) | (2860) | (3600) | (2650) | |
| Length (mm) | 1350 | | | |
| Height (mm) | 1900 | 2155 | 1750 | |
| Total mass (Dry state) (kg) | 2900 | 3400 | 2500 | 3200 |
| Noise level (dB (A)) | 78 | 78 | 74 | 74 |
| EB-unit (kW/m³/min) | 5.26 | 5.77 | 5.26 | 5.77 |

◎ Noise values measured in noiseless environment at distance of 1.5meters from front, at height of 1m, with load of 100% (at 0.7MPa)
 ◎ Cooling water volume (water temp. 32): 100kW: 130L/min; 150kW: 200L/min

Notation

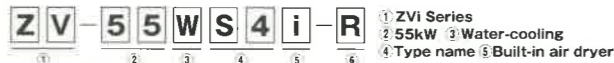

• Scroll 3.7kW / 5.5kW

| model | ESCAL 45R | ESCAL 48R | ESCAL 65R | ESCAL 68R |
|-----------------------------------|---|-----------|-----------|-----------|
| Delivered air pressure (MPa) | 0.83 | | | |
| Free air delivery (m³/min) | 0.47 | | 0.73 | |
| Intake air pressure & temperature | Atmospheric pressure (2~40°C) | | | |
| Main motor power (kW) | Select the auto start/stop or unloader type | | | |
| Power source voltage (50/60Hz,V) | 3.7 | | 5.5 | |
| Motor type | 200/200-220 | | | |
| Starter | 3-phase squirrel cage, 4P totally-enclosed external fan | | | |
| Drive system | Direct ON start | | | |
| Cooling system | V belt drive | | | |
| Fan motor power (kW) | Air cooled | | | |
| Oil fill ration (L) | 3.5 | | 4.5 | |
| Air dew point at outlet (°C) | 10 (under applied pressure) * | | | |
| Cooling medium (kW) | 0.35 | 0.415 | 0.35 | 0.415 |
| Discharge pipe diameter (R) | 1/2 | | | |
| Width (Dryer less) (mm) | 785 | | | |
| Length (mm) | 505 | | | |
| Height (mm) | 1140 (790) | | | |
| Total mass (Dry state) (kg) | 234 | | 254 | |
| Noise level (dB (A)) | 49 | | 52 | |
| EB-unit (kW/m³/min) | 7.87 | | 7.53 | |

* Values with ambient temperature of 30; and rated discharge pressure.
 ◎ Noise values measured in noiseless environment at distance of 1.5meters from front, at height of 1m, with load of 100% (at 0.83MPa)

Safety instructions

- Free air delivery is the volume of delivery air discharged when air pressure is applied to the intake (atmospheric pressure). (JIS B 8341)
- Do not use delivery air for respirator equipment whose discharge is inhaled directly.
- Maintain ventilation so that intake air temperature does not exceed 40°. Use the compressor indoors.
- Contact us for guaranteed values.
- Do not drain water discharge from the compressor directly into rain gutters. Follow any applicable wastewater regulations. Please contact your Mitsui Seiki sales representative if you have any questions or problems.

Zgaiard Z series

• Basic 7.5kW~37kW

| model | Z085A83-R | Z086A83-R | Z115AS3-R | Z116AS3-R | Z155AS3-R | Z156AS3-R | Z225AS3-R | Z226AS3-R | Z375AS3-R | Z376AS3-R |
|-----------------------------------|---|-------------|-----------|-------------|-------------|-------------------------------|-------------|-----------|-------------|-----------|
| Delivered air pressure (MPa) | 0.7 | | | | | | | | | |
| Free air delivery (m³/min) | 1.2 | | 1.8 | | 2.6 | | 3.9 | | 6.5 | |
| Intake air pressure & temperature | Atmospheric pressure (2~40°C) | | | | | | | | | |
| Capacity control method | Power-saving AUCS Automatic start/stop selection | | | | | | | | | |
| Main motor power (kW) | 7.5 | | 11 | | 15 | | 22 | | 37 | |
| Power source voltage (50/60Hz,V) | 200/200-220 | | | | | | | | | |
| Motor type | 3-phase squirrel cage, 2P totally-enclosed external fan | | | | | | | | | |
| Starter | Direct ON start | | | | | 3-contactor, star delta start | | | | |
| Drive system | Direct coupled motor | | | | | | | | | |
| Cooling system | Air cooled | | | | | | | | | |
| Fan motor power (kW) | 0.4 | | 0.9 | | 2.2 | | 2.2 | | 2.2 | |
| Oil fill ration (L) | 10 | | 13 | | 15 | | 20 | | 20 | |
| Air dew point at outlet (°C) | 10 (under applied pressure) * | | | | | | | | | |
| Cooling medium (kW) | 0.382 | 0.454-0.458 | 0.382 | 0.454-0.458 | 0.54 | 0.602-0.626 | 1.5 | 1.9 | 1.5 | 1.9 |
| Discharge pipe diameter (R) | 3/4 | | 1 | | 1 1/2 | | 1 1/2 | | 1 1/2 | |
| Width (Dryer less) (mm) | 905 | | 1050 | | 1280 (1160) | | 1750 (1550) | | 1750 (1550) | |
| Length (mm) | 705 | | 750 | | 1200 | | | | | |
| Height (mm) | 1400 | | 1450 | | 1490 | | 1550 | | 1550 | |
| Total mass (Dry state) (kg) | 410 | 430 | 540 | 640 | 950 | 950 | 950 | 950 | 950 | 950 |
| Noise level (dB (A)) | 53 | 55 | 56 | 54 | 59 | 59 | 59 | 59 | 59 | 59 |
| EB-unit (kW/m³/min) | 6.25 | 6.11 | 6.11 | 5.77 | 5.64 | 5.64 | 5.64 | 5.64 | 5.69 | 5.69 |

* Values with ambient temperature of 30; and rated discharge pressure.
 ◎ Values in () are the free air delivery for 0.93MPa specification (option)
 ◎ Noise values measured in noiseless environment at distance of 1.5meters from front, at height of 1m, with load of 100% (at 0.7MPa)
 ◎ Specifications for 22 to 37kW water-cooled unit available on request (option)

• Basic 55kW~75kW

| model | Z555AS3-R | Z556AS3-R | Z755AS3-R | Z756AS3-R | Z555WS3-R | Z556WS3-R | Z755WS3-R | Z756WS3-R |
|-----------------------------------|---|-----------|-------------|-----------|--------------|-----------|-------------|-----------|
| Delivered air pressure (MPa) | 0.7 | | | | | | | |
| Free air delivery (m³/min) | 9.5 | | 13.0 | | 9.5 | | 13.0 | |
| Intake air pressure & temperature | Atmospheric pressure (2~40°C) | | | | | | | |
| Capacity control method | Power-saving AUCS Automatic start/stop selection | | | | | | | |
| Main motor power (kW) | 55 | | 75 | | 55 | | 75 | |
| Power source voltage (50/60Hz,V) | 200/200-220 | | | | | | | |
| Motor type | 3-phase squirrel cage, 2P totally-enclosed external fan | | | | | | | |
| Starter | 3-contactor, star delta start | | | | | | | |
| Drive system | Direct coupled motor | | | | | | | |
| Cooling system | Air cooled | | | | Water cooled | | | |
| Fan motor power (kW) | 3.0 | | 0.08 | | 0.12 | | 0.12 | |
| Oil fill ration (L) | 60 | | 60 | | 60 | | 60 | |
| Air dew point at outlet (°C) | 10 (under applied pressure) * | | | | | | | |
| Cooling medium (kW) | 1.9 | 2.4 | 2.4 | 2.8 | 1.9 | 2.4 | 1.9 | 2.4 |
| Discharge pipe diameter (R) | 2 | | 2 | | 2 | | 2 | |
| Width (Dryer less) (mm) | 1990 (1550) | | 2240 (1800) | | 1990 (1550) | | 2240 (1800) | |
| Length (mm) | 1200 | | | | 1700 | | | |
| Height (mm) | 1700 | | | | 1700 | | | |
| Total mass (Dry state) (kg) | 1510 | 1800 | 1500 | 1770 | 1510 | 1800 | 1500 | 1770 |
| Noise level (dB (A)) | 66 | 69 | 65 | 66 | 66 | 69 | 65 | 66 |
| EB-unit (kW/m³/min) | 5.79 | 5.77 | 5.77 | 5.77 | 5.79 | 5.77 | 5.77 | 5.77 |

* Values with ambient temperature of 30; and rated discharge pressure.
 ◎ Values in () are the free air delivery for 0.93MPa specification (option)
 ◎ Noise values measured in noiseless environment at distance of 1.5meters from front, at height of 1m, with load of 100% (at 0.7MPa)
 ◎ Cooling water volume (water temp. 32): 55kW: 80L/min; 75kW: 110L/min

• Basic 100kW~150kW

| model | Z1005AS | Z1006AS | Z1505AS | Z1506AS | Z1005WS | Z1006WS | Z1505WS | Z1506WS |
|-----------------------------------|---|---------|---------|---------|--------------|---------|---------|---------|
| Delivered air pressure (MPa) | 0.7 | | | | | | | |
| Free air delivery (m³/min) | 19.0 | 18.2 | 27.0 | 26.0 | 19.0 | 18.2 | 27.0 | 26.0 |
| Intake air pressure & temperature | Atmospheric pressure (2~40°C) | | | | | | | |
| Capacity control method | Power-saving AUCS Automatic start/stop selection | | | | | | | |
| Main motor power (kW) | 100 | | 150 | | 100 | | 150 | |
| Power source voltage (50/60Hz,V) | 400/440 | | | | | | | |
| Motor type | 3-phase squirrel cage, 2P totally-enclosed external fan | | | | | | | |
| Starter | 3-contactor, star delta start | | | | | | | |
| Drive system | Direct coupled motor | | | | | | | |
| Cooling system | Air cooled | | | | Water cooled | | | |
| Fan motor power (kW) | 5.5 | | 0.08 | | 0.12 | | 0.12 | |
| Oil fill ration (L) | 80 | | 100 | | 80 | | 100 | |
| Discharge pipe diameter (R) | JIS 3B (80A) Flange | | | | | | | |
| Width (Dryer less) (mm) | (2860) | | (3200) | | (2860) | | (2860) | |
| Length (mm) | 1350 | | | | 1750 | | | |
| Height (mm) | 1900 | 2155 | 1900 | 2155 | 1900 | 2155 | 1900 | 2155 |
| Total mass (Dry state) (kg) | 2750 | 3410 | 2750 | 3410 | 2750 | 3410 | 2750 | 3410 |
| Noise level (dB (A)) | 78 | | 78 | | 74 | | 74 | |
| EB-unit (kW/m³/min) | 5.26 | 5.49 | 5.56 | 5.77 | 5.26 | 5.49 | 5.56 | 5.77 |

◎ Values in () are the free air delivery for 0.88MPa specification (option)
 ◎ Noise values measured in noiseless environment at distance of 1.5meters from front, at height of 1m, with load of 100% (at 0.7MPa)
 ◎ Cooling water volume (water temp. 32): 100kW: 130L/min; 150kW: 200L/min

Notation



Compressor installation

Precautions for installation location

Some installation environments can damage the compressor or cause malfunctions. Please follow the precautions below in order to ensure the efficient, safe, and long-term use of your compressor.

Installation environment

- ▲ Avoid installing outdoors, in semi-outdoor locations, in locations exposed to rain, and the like.
- ▲ Avoid installing in locations exposed to dust or toxic gases.
- ▲ Install in a location with an ambient temperature between 2 and 40. (We recommend the optional cold-weather specification if installing in temperatures of 2; and lower)

Location

- ▲ Install on a firm, level floor.
- ▲ Install in a spacious, well lit location enabling operation to be monitored easily.
- ▲ There should be no impediments to transporting the unit to/from the location or performing maintenance.

Electrical wiring

- ▲ All electrical wiring during installation must be done in accordance with technical standards. Electrical leaks, worn insulation, overcurrent, short circuits, open-phase driving, and defective protective equipment could cause sparks from the electrical wiring or electronic circuits.
- ▲ Install a non-fuse breaker on the main power line if the model so requires.
- ▲ Connect a ground cable to prevent electrical leaks.
- ▲ Never remove protective equipment or perform modifications that disables an electronic circuit's protective features.

Maintenance

- ▲ We recommend conducting maintenance and inspection ahead of the standard schedule in accordance with the installation environment and location.

Ventilation

- ▲ The compressor room must be ventilated. Install a ventilation fan, duct, or the like so that the ambient temperature does not exceed 40; Failure to do so could cause the compressor to overheat, or damage the insulation of electrical components.

Installation space

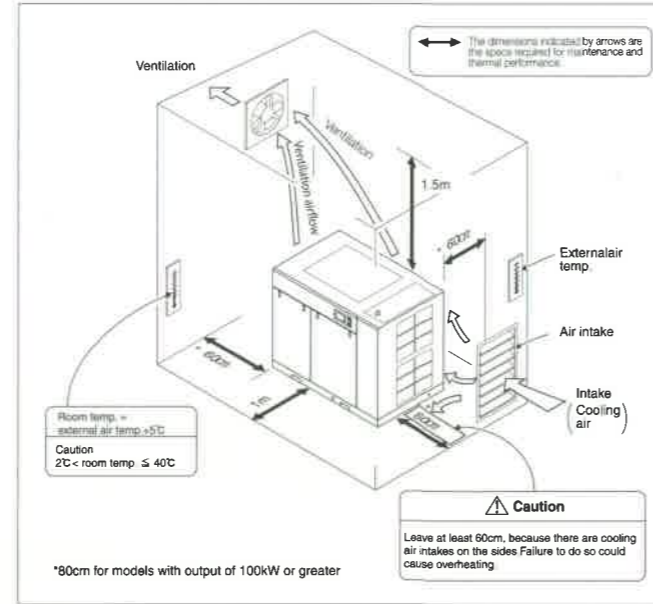

Ventilating the compressor room

Be very careful to ventilate the compressor room!

The compressor room must be ventilated. Install a ventilation fan, duct, or the like so that the ambient temperature does not exceed 40°C. Failure to do so could cause the compressor to overheat, or damage the insulation of electrical components.

Ventilation volume

Some installation environments can damage the compressor or cause malfunctions. Please follow the precautions below in order to ensure the efficient, safe, and long-term use of your compressor.

Installation environment

- ▲ Avoid installing outdoors, in semi-outdoor locations, in locations exposed to rain, and the like.
- ▲ Avoid installing in locations exposed to dust or toxic gases.
- ▲ Install in a location with an ambient temperature between 2 and 40. (We recommend the optional cold-weather specification if installing in temperatures of 2; and lower)

| | Figure A. Overall ventilation | Figure B. Duct ventilation (ventilation via main unit exhaust fan only) |
|--------------------|--|--|
| Ventilation method | | |
| Precautions | <p>This is the most common ventilation method. See the table below (Fig. A) for the ventilation volume when the compressor is installed in a small room, and you ventilate the room as a whole. (This assumes an increase of 5°C of the permissible temperature in the room.) Install the ventilation fan in a high location, and the air intake in a low location facing the side of the compressor where the air intake is located. Ensure that the airflow at the air intake is no more than 2m/sec.</p> <p>Air intake (B)=Ventilation (A) + Free air delivery</p> | <p>Calculate the resistance of the ventilation duct based on the volume of exhaust from the compressor, and determine a duct shape such that the pressure loss is no more than 20Pa (2mm Aq). The duct construction should be removable in order to facilitate maintenance. Note that noise may leak outside via the ventilation duct aperture. A ventilation fan must be installed in order to transport the exhaust from the dryer.</p> <p>Air intake (E)=Ventilation (C) + Heat exhaust (D or D+F) + Free air delivery</p> |

Selected examples of installation Please consult with Mitsui Seiki or a designated service shop for details.

| Model | Non-fuse breaker | | Power transformer Capacity (200/400V) | Secondary wiring cable 22 kW or 10 m, 37 kW or 20 m | | | | Cooling tower For CT outlet temp. of 32°C |
|--------------------|---------------------|---------------------|--|--|-----------------|-----------|-----------------|--|
| | 200/220V | 400/440V | | 200/220V | Grounding cable | 400/440V | Grounding cable | |
| Z08AS3-R(Zgaiard) | 100AF-60AT | 30AF-30AT | 10KVA | 8mm²M5 | 5.5mm²M5 | 3.5mm²M4 | 5.5mm²M4 | — |
| Z11AS3-R(Zgaiard) | 100AF-75AT | 50AF-50AT | 15KVA | 14mm²M5 | 14mm²M5 | 5.5mm²M4 | 14mm²M5 | — |
| Z15AS3-R(Zgaiard) | 100AF-100AT | 100AF-60AT | 20KVA | 22mm²M8 | 14mm²M5 | 14mm²M5 | 14mm²M5 | — |
| Z15AS2H-R | 100AF-100AT | 100AF-60AT | 20KVA | 22mm²M8 | 14mm²M5 | 14mm²M5 | 14mm²M5 | — |
| Z22AS2H-R | 225AF-175AT | 100AF-100AT | 30KVA | 38mm²M10 | 22mm²M5 | 22mm²M8 | 22mm²M5 | — |
| Z22AS3-R(Zgaiard) | 225AF-175AT | 100AF-100AT | 30KVA | 38mm²M10 | 22mm²M5 | 22mm²M8 | 22mm²M5 | 10t or more |
| Z37AS3-R(Zgaiard) | NF250-SEW,HEW-225AT | NF250-SEW,HEW-150AT | 50KVA | 100mm²M10 | 22mm²M5 | 38mm²M8 | 22mm²M5 | 10t or more |
| Z55AS3-R(Zgaiard) | 400AF-400AT | 225AF-225AT | 70KVA | 150mm²M12 | 38mm²M8 | 60mm²M10 | 38mm²M8 | 15t or more |
| Z55WS3-R(Zgaiard) | 400AF-400AT | 225AF-225AT | 70KVA | 150mm²M12 | 38mm²M8 | 60mm²M10 | 38mm²M8 | 15t or more |
| Z75AS3-R(Zgaiard) | NF400-SEW,HEW-400AT | NF250-SEW,HEW-225AT | 150KVA | 200mm²M12 | 38mm²M8 | 60mm²M10 | 38mm²M8 | 20t or more |
| Z75WS3-R(Zgaiard) | NF400-SEW,HEW-400AT | NF250-SEW,HEW-225AT | 150KVA | 200mm²M12 | 38mm²M8 | 60mm²M10 | 38mm²M8 | 20t or more |
| Z100AS(Zgaiard) | — | 400AF-400AT | 150KVA | — | — | 150mm²M12 | 38mm²M8 | 30t or more |
| Z100WS(Zgaiard) | — | 400AF-400AT | 150KVA | — | — | 150mm²M12 | 38mm²M8 | 30t or more |
| Z150AS(Zgaiard) | — | NF400-SEW,HEW-400AT | 300KVA | — | — | 250mm²M12 | 60mm²M8 | 40t or more |
| Z150WS(Zgaiard) | — | NF400-SEW,HEW-400AT | 300KVA | — | — | 250mm²M12 | 60mm²M8 | 40t or more |
| ZV08AS4-R(Zgaiard) | 50AF-50AT | 30AF-30AT | 15KVA | 5.5mm²M6 | 5.5mm²M6 | 2mm²M6 | 2mm²M6 | — |
| ZV11AS4-R(Zgaiard) | 100AF-75AT | 50AF-40AT | 20KVA | 8mm²M6 | 8mm²M6 | 3.5mm²M6 | 3.5mm²M6 | — |
| ZV15AS4-R(Zgaiard) | 225AF-125AT | 100AF-60AT | *24/31KVA | 22mm²M8 | 14mm²M8 | 8mm²M6 | 8mm²M6 | — |
| ZV22AS4-R(Zgaiard) | 225AF-150AT | 100AF-75AT | *31/33KVA | 38mm²M8 | 22mm²M8 | 14mm²M6 | 14mm²M6 | 10t or more |
| ZV37AS4-R(Zgaiard) | 225AF-225AT | 225AF-125AT | *52/59KVA | 80mm²M10 | 38mm²M10 | 22mm²M8 | 22mm²M8 | 10t or more |
| ZV55AS4-R(Zgaiard) | 400AF-350AT | 225AF-175AT | *75/73KVA | 100mm²M10 | 38mm²M10 | 60mm²M8 | 22mm²M8 | 15t or more |
| ZV55WS4-R(Zgaiard) | 400AF-350AT | 225AF-175AT | *75/73KVA | 100mm²M10 | 38mm²M10 | 60mm²M8 | 22mm²M8 | 15t or more |
| ZV75AS4-R(Zgaiard) | 400AF-400AT | 225AF-225AT | 110KVA | 125mm²M12 | 38mm²M12 | 60mm²M10 | 38mm²M10 | 20t or more |
| ZV75WS4-R(Zgaiard) | 400AF-400AT | 225AF-225AT | 110KVA | 125mm²M12 | 38mm²M12 | 60mm²M10 | 38mm²M10 | 20t or more |
| ZV100ASi(Zgaiard) | — | 400AF-250AT | 200KVA | — | — | 80mm²M12 | 38mm²M12 | 30t or more |
| ZV100WSi(Zgaiard) | — | 400AF-250AT | 200KVA | — | — | 80mm²M12 | 38mm²M12 | 30t or more |
| ZV150ASi(Zgaiard) | — | 400AF-350AT | 250KVA | — | — | 100mm²M12 | 38mm²M12 | 40t or more |
| ZV150WSi(Zgaiard) | — | 400AF-350AT | 250KVA | — | — | 100mm²M12 | 38mm²M12 | 40t or more |
| ESCAL4R | 30AF-30AT | 30AF-20AT | 5KVA | 3.5mm²M4 | 3.5mm²M4 | 2mm²M4 | 2mm²M4 | — |
| ESCAL6R | 50AF-50AT | 30AF-30AT | 10KVA | 5.5mm²M4 | 5.5mm²M4 | 3.5mm²M4 | 3.5mm²M4 | — |

- Use a recommended SEW or HEW circuit breaker (made by Mitsubishi Electric Corporation). (If changing in same frame)
- If you use our designated NF series of non-fuse circuit breakers, use the NV series of designated leak-electricity circuit breakers (made by Mitsubishi Electric Corporation).
- Use power lines with a size of 55kW or less when the continuous maximum allowed temp. is 75; (e.g. NIV power lines). If the ambient temperature is 50; or less, it is assumed that the wiring separation will be 20m or less.
- Use power lines with a size of 75kW or more when the continuous maximum allowed temp. is 90; (e.g. LMFC power lines). If the ambient temperature is 50; or less, it is assumed that the wiring separation will be 20m or less.

Ventilation volume Please consult with Mitsui Seiki or a designated service shop for details.

| Model | Heat output (MJ/h) | | Compressor exhaust volume (m³/min) Fig.B (D) | | Ventilation volume (m³/min) Fig.A (A) | | Ventilation volume (m³/min) Fig.B (C) | |
|--------------------|--------------------|------------|--|--------------------------------|---------------------------------------|------------|---------------------------------------|------------|
| | Dryerless | With dryer | Dryerless (~50/60Hz) (D) | With dryer (~50/60Hz) (D+E) | Dryerless | With dryer | Dryerless | With dryer |
| Z08AS3-R(Zgaiard) | 27 | 32 | 15 | 31 | 75 | 89 | 4 | 18 |
| Z11AS3-R(Zgaiard) | 40 | 46 | 25 | 41 | 109 | 124 | 6 | 20 |
| Z15AS3-R(Zgaiard) | 54 | 61 | 33 | 49 | 149 | 169 | 8 | 28 |
| Z15AS2H-R | 54 | 62 | 40 | 67 | 149 | 171 | 8 | 30 |
| Z22AS2H-R | 79 | 93 | 65 | 96 | 219 | 257 | 11 | 49 |
| Z22AS3-R(Zgaiard) | 79 | 91 | 35 | 66 | 219 | 254 | 11 | 45 |
| Z37AS3-R(Zgaiard) | 133 | 152 | 50 | 97 | 368 | 419 | 19 | 69 |
| Z55AS3-R(Zgaiard) | 188 | 225 | *131/160 | *209/238 | 547 | 623 | 28 | 103 |
| Z55WS3-R(Zgaiard) | 40 | 67 | 36 | 114 | 109 | 185 | 6 | 81 |
| Z75AS3-R(Zgaiard) | 270 | 303 | *157/161 | *235/239 | 747 | 837 | 38 | 128 |
| Z75WS3-R(Zgaiard) | 54 | 87 | 36 | 114 | 149 | 240 | 8 | 99 |
| Z100AS(Zgaiard) | 360 | — | *310/380 | — | 1000 | — | 50 | — |
| Z100WS(Zgaiard) | 72 | — | *42/50 | — | 200 | — | 10 | — |
| Z150AS(Zgaiard) | 540 | — | *400/430 | — | 1500 | — | 75 | — |
| Z150WS(Zgaiard) | 108 | — | *42/50 | — | 300 | — | 15 | — |
| ZV08AS4-R(Zgaiard) | 27 | 32 | 15 | 31 | 75 | 89 | 4 | 18 |
| ZV11AS4-R(Zgaiard) | 40 | 45 | 20 | 36 | 109 | 124 | 6 | 20 |
| ZV15AS4-R(Zgaiard) | 54 | 61 | 25 | 41 | 149 | 169 | 8 | 28 |
| ZV22AS4-R(Zgaiard) | 79 | 91 | 35 | 66 | 219 | 254 | 11 | 45 |
| ZV37AS4-R(Zgaiard) | 133 | 152 | 50 | 97 | 368 | 419 | 19 | 69 |
| ZV55AS4-R(Zgaiard) | 198 | 225 | 120 | 198 | 547 | 623 | 28 | 103 |
| ZV55WS4-R(Zgaiard) | 40 | 67 | 36 | 114 | 109 | 185 | 6 | 81 |
| ZV75AS4-R(Zgaiard) | 270 | 303 | 190 | 268 | 747 | 837 | 38 | 128 |
| ZV75WS4-R(Zgaiard) | 54 | 87 | 72 | 150 | 149 | 240 | 8 | 99 |
| ZV100ASi(Zgaiard) | 360 | — | 310 | — | 1000 | — | 50 | — |
| ZV100WSi(Zgaiard) | 72 | — | 42 | — | 200 | — | 10 | — |
| ZV150ASi(Zgaiard) | 540 | — | 400 | — | 1500 | — | 75 | — |
| ZV150WSi(Zgaiard) | 108 | — | 42 | — | 300 | — | 15 | — |
| ESCAL4R | 14 | 16 | 15 | 40 | 39 | 44 | 2 | 8 |
| ESCAL6R | 20 | 23 | 19 | 48 | 55 | 62 | 3 | 11 |

Calculating ventilation requirement

$$Q = \frac{n \times H \times 1000}{1.2 \times \Delta T \times 60}$$

- Q: Required ventilation volume (m³/min)
- H: Heat output per unit (MJ/h)
- n: Number of units
- ΔT: Tolerated temperature rise (t1-t0)
- (t1: tolerated indoor temp. (°C); t0: outside temp. (°C)) T is generally calculated as 5°C.

Piping

- Do not connect pipes with union joints or flange joints, so that they do not impede overhauls and the like.
- Make sure that the diameter of the main pipe is at least as large as the discharge outlet, in order to minimize the drop in pressure. Install an approximately 1/100 slope to enable draining from the piping.
- Use a pipe diameter with enough leeway to reduce resistance, in accordance with the installed length of the piping.
- Install stop valves on the compressor discharge outlet, on both the user side and discharge side, in order to facilitate maintenance.
- Install air tanks, filters, and the like as needed, in accordance with the plant's air usage.
- See the installation manual for further details.

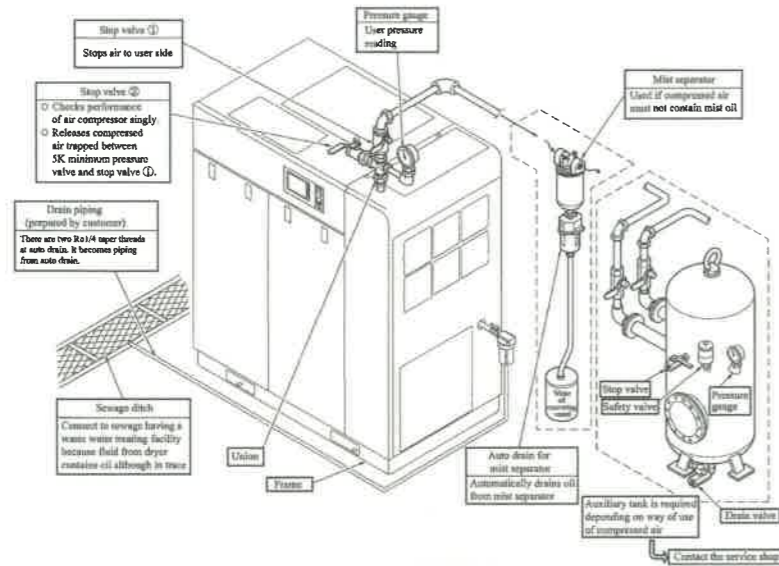

Warning

If stop valve ② illustrated above is below, compressed air would remain in SK minimum pressure valve, after cooler, dryer and stop valve ① and maintenance could be impossible upon removing the dryer auto drain or its piping. If piping is detached as it is, air would jet out strongly. Be sure to mount the stop valve ② shown above.

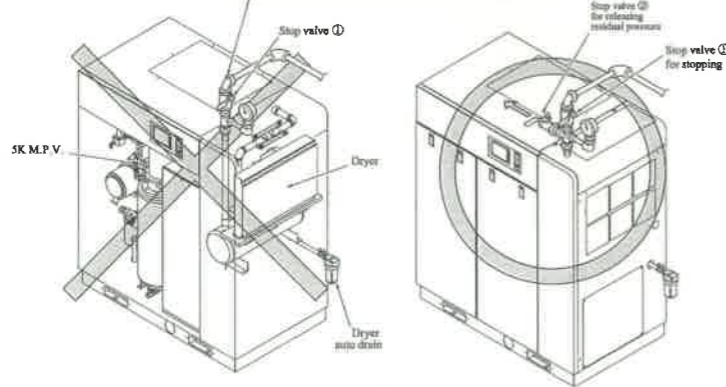

Stop valve ② is mandatory.

Pure oil

MITSUI genuine Compressor oil is lubrication oil developed for the Z screw. It is made up to fully perform its function and survive the long time operation. Please care to use the MITSUI genuine oil for the MITSUI products. Also pay attention not to use it mixed with another type oil.



Z-6000



Z-3000

Energy saving diagnosis

Attempts energy reduction of total facilities by a realistic implementation plan in view of general standpoint. Proposing a plan in view of "contribution to earth environment" in a middle term viewpoint and switching to clean energy.



Maintenance

[Oil type]

- Check the oil level of the Compressor every day.
- Adjust the amount of the drain (water) from the oil chamber in proportion to the load condition.
- Life cycle of the compressor oil is approximately 6,000 hours (for genuine oil Z-6000 compressor oil). Replace the oil immediately after passed the life cycle. Sooner replacement, if necessary as the dirt condition even not attained 6,000 hours, would help maintain good condition.

- Life cycle of the oil separator element is approximately 6,000 hours. Replace the oil immediately after passed the life cycle.
- Life cycle of the oil filter is approximately 6,000 hours. Replace the oil immediately after passed the life cycle. (Replacement period for the compressor oil, oil separator and oil filter shall become sooner according to the application circumstance).
- If a dust filter is blocking, it cause trouble. Clean filters regularly.
- Replace the Air cleaner element if the Monitor lamp lights up.
- Use Mitsui Seiki dedicated parts for maintenance part certainly.
- Execute other maintenance work based on Instruction Manual.

Have maintenance performed by a Mitsui Seiki Kogyo-certified technician (a service shop designated by Mitsui Seiki Kogyo).

Industrial Health and Safety Law
"Ordinance on Safety of Boilers and Pressure Vessels"

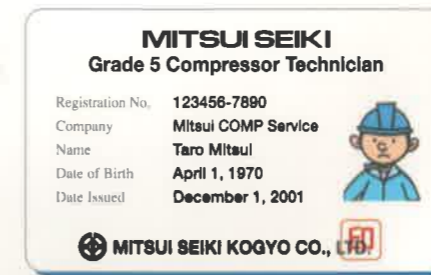

Mitsui Seiki Kogyo Technician Certificate

We distribute guides for safely installing and maintaining your compressor (published by the Japan Society of Industrial Machinery Manufacturers). Please read them together with your operation manual.



"Safe air compressor installation"



"Maintenance tips for safe, energy-efficient use of air compressors"

Laws and regulations relating to compressors

Industrial Health and Safety Law "Ordinance on Safety of Boilers and Pressure Vessels"

[Overview]

- Vessels with maximum pressure of 0.2MPa or higher, with capacity of 40L or higher
- Vessels with maximum pressure of 0.2MPa or higher, with internal diameter of 200mm or more, and length of 1,000mm or more

[Documents to submit]

- Second-class Pressure Vessel Description Handling Instructions
 - Second-class Pressure Vessel Description (Original)
- ⓄNote: It is not necessary to submit these document, but keep them in a secure place, because they are important.

[Installation and use]

- Pressure vessels cannot be modified
- Perform self inspections at least once a year, and keep a record
- Adjust pressure delivered by safety valve
- Use a pressure gage with a maximum meter reading of 1.5 to 3 times the maximum pressure used, with a display that makes it easy to check the maximum pressure used.

Basic Environment Law "Noise Abatement Act/Vibration Control Law"

[Overview]

- Applies to compressors with rated drive output of 7.5kW or more. Check with the Pollution Section of your municipal office, because the regulation values differ by prefecture.

[Documents to submit]

- At least 30days before installing the compressor, you must submit a notice of start or change of construction to your prefectural government via the Pollution Section of your municipal government.

[Installation and use]

- The noise and vibration at the boundary of the plant grounds must be within the regulated levels.

Laws and regulations relating to the environment and energy conservation

Energy conservation laws (Energy Conservation Act)

Enacted April 1, 2006 (revision)

- Purpose: Reduce average annual energy per unit of production by at least 1%.
- Key points of revision: Improve energy efficiency measures of factories and offices obligated to conserve energy through the central management of heating and electricity.

Global warming laws (Law for the Promotion of Measures to Deal with Global Warming)

Enacted April 1, 2006 (revision)

- Kyoto Protocol Target Achievement Plan: The target is to reduce CO₂ emissions from industry by 8.6% from 1990 levels by the year 2010.
- Key points of revision: A system for calculating, reporting, and publishing greenhouse gases was introduced.

mitsui seiki

<http://www.mitsui-seiki.co.jp>



JQA-0904



JQA-EM2883



Home office plant

MITSUI SEIKI KOGYO CO., LTD.

6-13 Hachiman, Kawajima-Machi, Hiki-Gun,
Saitama, 350-0193, JAPAN
Phone +81-49-297-8711 Fax +81-49-297-5377

MITSUI SEIKI (THAILAND) CO., LTD.

204/956 City Park Moo1, Soi Emthai, Teparak (k.m.22),
T. Bangsaothong, A. Bangsaothong, Samutprakarn, 10540, THAILAND
Phone +66 (0) 2-313-1881 Fax +66 (0) 2-313-1883

MITSUI SEIKI (SHANGHAI) SERVICE CO., LTD.

No28, Minyi Rd. Xinqiao, Songjiang, Shanghai, 201612, CHINA
Phone +86 (0) 21-5768-7460 Fax +86 (0) 21-5768-6891

Contact information
Trusted Mitsui Seiki distributors